

**NOTES:**

- REINFORCED PRECAST CONCRETE MANHOLES SHALL CONFORM TO THE APPLICABLE REQUIREMENTS OF ASTM C-478 AND:
  - SHALL BE DESIGNED FOR AASHO H-20 LOADING.
  - CONCRETE SHALL BE COMPACTLY VIBRATED, CENTRIFUGALLY SPUN, OR MECHANICALLY TAMPED.
- SEWER MAINS ARE TO BE LAID THRU THE MANHOLE WHERE POSSIBLE AND USED AS A FORM FOR THE INVERT. THE TOP 1/2 DIAMETER OF THE PIPE IS TO BE BROKEN OUT TO A NEAT LINE. BROKEN EDGES SHALL BE PLASTERED SMOOTH WITH CEMENT MORTAR.
- CONCRETE BASE SHALL BE OF CLASS "A" CONCRETE AND PLACED IN ONE OPERATION. CONCRETE INVERTS SHALL BE TRUE TO GRADE AND ALIGNMENT AND FINISHED WITH A SMOOTH SURFACE. SPECIAL CARE SHALL BE USED IN FORMING ALL CHANNELS TO FACILITATE THE FLOW OF SEWAGE.
- SHALLOW MANHOLE AS SHOWN HEREON TO BE INSTALLED WHEN DEPTH TO PIPE SHELF IS LESS THAN 5' FROM FINISHED STREET GRADE.
- SEE DRAWING SB-61 FOR DETAILS AND INSTALLATION OF MANHOLECOVER AND FRAME.
- MANHOLE STEP (ONE STEP ONLY) SHALL BE EITHER CAST IN PLACE OR M.A. INDUSTRIES STEEL REINFORCED COPOLYMER POLYPROPYLENE PLASTIC DRIVE-IN STEP. INSTALLATION TO BE BY MANHOLE MANUFACTURER. STEP ORIENTED 180° FROM MANHOLE OUTLET. STEP SHALL BE CAST IN PLACE TO BE USED AS CLEANING HOOK AND SHALL BE PLACED 6" MIN AND 12" MAX FROM TOP OF SHELF.

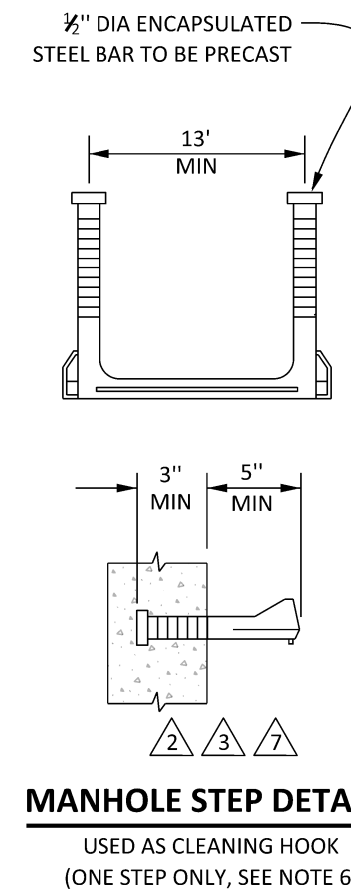
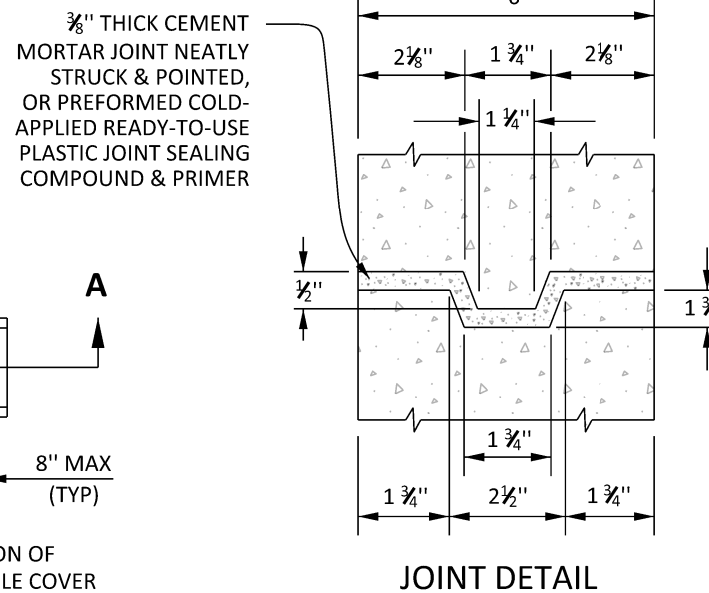
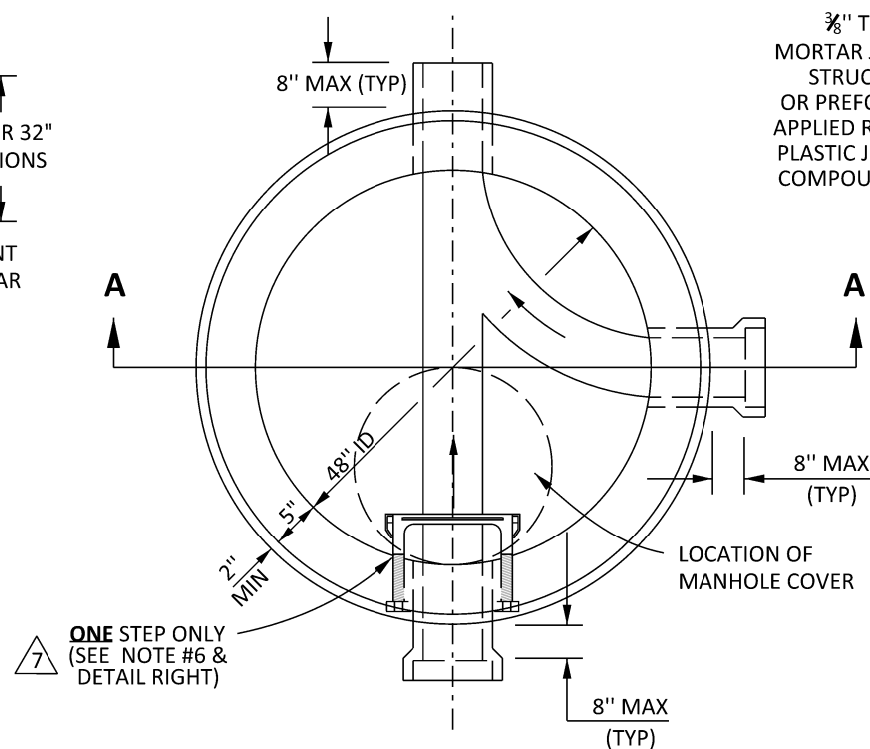
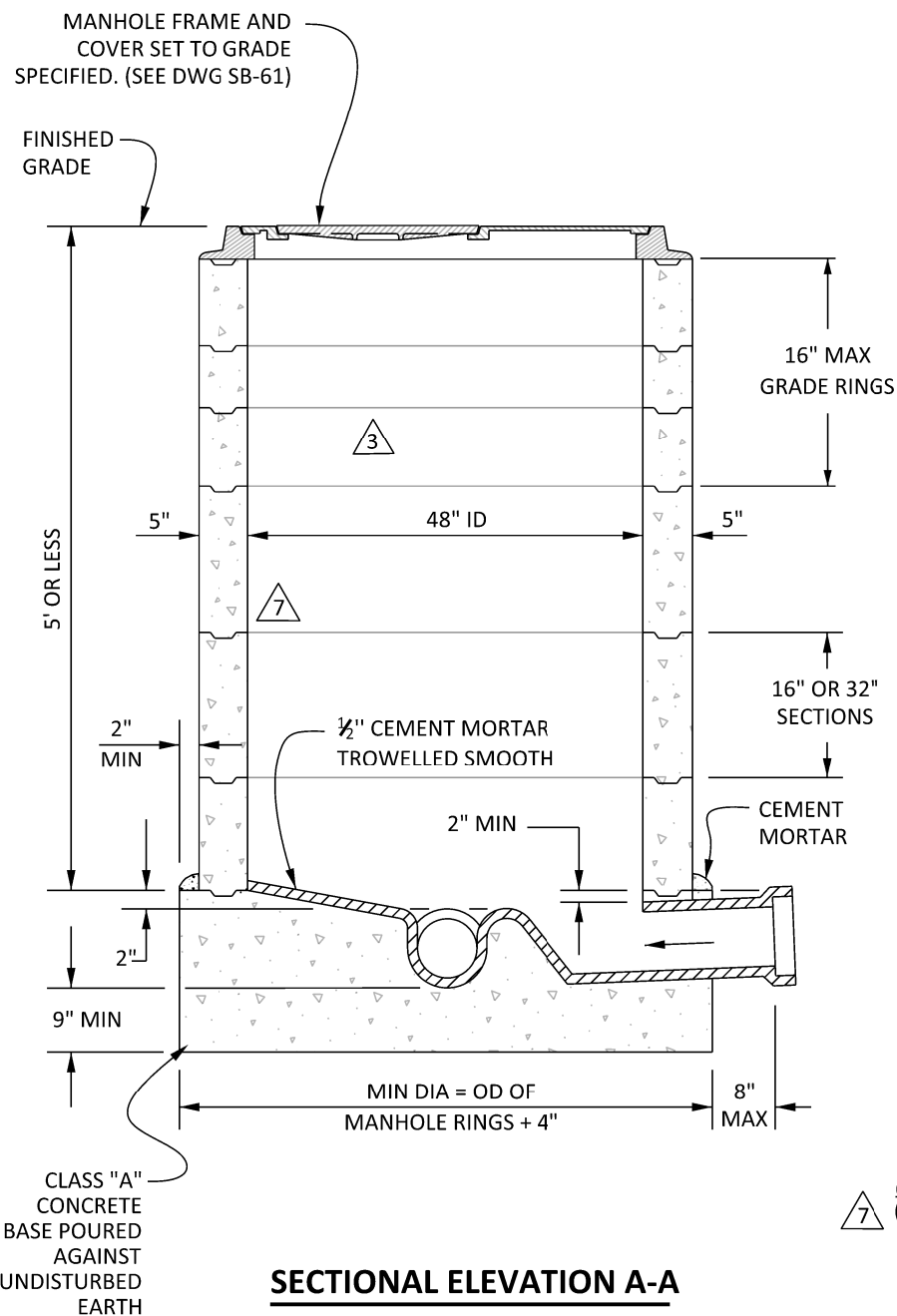

REVISIONS				APPROVALS			
NO.	DATE	INITIAL	DESCRIPTION	APP'D	DATE	INITIAL	DATE
3	7/7/21	GS	REVISED MANHOLE STEP NOTE 6 AND DETAILS	AGA	7/7/21	CJS	4/20/72
6	7/3/19	GS	UPDATED TITLE BLOCK, FONT, LOGO AND PAGE LAYOUT	AGA	7/3/19		
5	3/5/01	GR	ADDED NEW TITLE BLOCK & FILE ID NO.	VJB	3/27/03		
4	7/21/97	KER	REVISED SHALLOW MANHOLE	VJB	10/29/97		
3	12/11/96	KER	REVISED STEP DETAIL AND NOTE 6	VJB	12/11/96	LM	4/24/72

EASTERN MUNICIPAL WATER DISTRICT

EASTERN MUNICIPAL WATER DISTRICT  
STANDARD DRAWING

**REINFORCED PRECAST SHALLOW MANHOLE**

REFERENCES:	SCALE: NONE
FILE I.D.: \kauai\eng\std dwgs\SB-30.dgn	DRAWN BY: KER

RECOMMENDED \_\_\_\_\_  
DIRECTOR OF ENGINEERING DATE

APPROVED Doyle J. Boen 4/72  
ASSISTANT GENERAL MANAGER DATE

**SB-30**