

| ITEM | QTY | DESCRIPTION |
|------|--------|---|
| ① | 1 | 8" METER * |
| ② | 2 | 12" OR 18" RESILIENT SEAT GATE VALVE FxF |
| ③ | 1 | 12" OR 18" VICTAULIC COUPLING |
| ④ | 1 | 12"x6" OR 18"x6" FLG x VICTAULIC NIPPLE |
| ⑤ | 1 | 12" OR 18" FLG x VICTAULIC NIPPLE (LENGTH VARIES) |
| ⑥ | 1 | 12" OR 18" F x F SPOOL (LENGTH VARIES) |
| ⑦ | 1 | 12"x24" OR 18"x24" FLANGED SPOOL |
| ⑧ | 15'+/- | 15'+/-2" COPPER TUBING TYPE K |
| ⑨ | 2 | 2"x90 DEG COPPER SWEAT ELL |
| ⑩ | 4 | 2" COPPER SWxIPM ADAPTER, (CORP STOP W/PVC) |
| ⑪ | 2 | 2-1/2"x4" SERVICE SADDLE W/2-1/2"x2"BRASS RED BUSHING, (2" SERVICE CLAMP W/PVC) |
| ⑫ | 1 | BLIND FLANGE (IF REQUIRED) |
| ⑬ | 1 | 2" BRASS CURB STOP |
| ⑭ | 1 | 12" OR 18" PIPE |
| ⑮ | 1 | UTILITY BOX/VAULT ** |
| ⑯ | 1 | TORSION SPRING 2-PC LID : PARKWAY OR TRAFFIC COVER (ALUMINUM), ROADWAY APPLIC. TO MEET AASHTO H-20 DIRECT TRAFFIC RATING (STEEL). |
| ⑰ | 1 | PRECAST CONCRETE BASE W/8" SUMP **** ① |
| ⑱ | 1 | WATER METER STRAINER |
| ⑲ | 1 | (IP) COUPLING AND PLUG (SEE NOTE 15) |

FLOW RATE TABLE ③

| FUTURE METER SIZE | FLOW RATE (GPM) | LATERAL SIZE | VELOCITY (FT/S) | METER LENGTH |
|-------------------|-----------------|--------------|-----------------|--------------|
| 8" OMNI C2 | 2700 | 12" | 7.5 | 30 1/8" |
| 8" OMNI T2 | 3500 | 12" | 9.8 | 30 1/8" |
| 8" OMNI C2 | 2700 | 18" | 3.4 | 30 1/8" |
| 8" OMNI T2 | 3500 | 18" | 4.4 | 30 1/8" |

NOTES:

- * 1. METER SUPPORT AS REQUIRED.
- ** 2. METER DIMENSIONS MAY VARY. CONTRACTOR SHALL VERIFY METER DIMS & SUPPLY UTILITY BOX WITH SPECIFIED CLEARANCE, WALL THICKNESS PER MANUFACTURER SPECIFICATION.
- 3. METER REGISTERS TO BE IN CUBIC FEET.
- **** 4. BASE IS INCLUDED W/VAULT.
- ③ 5. READ HOLES ARE TO BE POSITIONED OVER METER REGISTERS AFTER METER IS INSTALLED PER B-976.
- 6. VAULT LIDS TO BE PRIMED & PAINTED EMWD APPROVED TAN.
- 7. ALL MATERIALS PER EMWD APPROVED MATERIAL LIST.
- 8. METER TYPE SHALL BE APPROVED BY NEW BUSINESS OR METER SERVICES.
- 9. DEPTH OF METER SHALL BE 5 FT. MAX. FROM VAULT LID TO TOP OF METER.
- ② 10. PROVIDE A MAXIMUM 4" CLEARANCE BETWEEN PIPE AND KNOCKOUT HOLE WITH A MINIMUM OF 6" CLEARANCE ABOVE THE VAULT FLOOR.
- ③ 11. CONTRACTOR SHALL RETURN AFTER ROAD SHOULDER OR PARKWAY IS COMPLETE TO INSTALL METER VAULT, AND SHALL BE RESPONSIBLE FOR COORDINATING WORK OF OTHER CONTRACTORS FOR SAFEGUARDING SERVICES UNTIL METER VAULT IS SET.
- ③ 12. ALL BARE IRON AND STEEL SHALL BE COATED WITH CEMENT MORTAR AS PER THE FIELD ENGINEER.
- ③ 13. VALVES AND OTHER APPURTENANCES AND FITTINGS AT THE PIPELINE SHALL BE PRIMED AND WRAPPED WITH PROTECTO-WRAP NO. 200 OR 300 TAR RESIN TAPE. BOLTS AND NUTS SHALL BE PROTECTED USING ZINC CAPS ANODES IN ACCORDANCE WITH SECTION 15089.
- ③ 14. RISER AND CAP SHALL BE INSTALLED PER B-668.
- ③ 15. TEST PORT (COUPLING & PLUG) SHALL BE 4" (IP).
- ③ 16. SYSTEMS WITH ONSITE PUMPS SHALL NOT EXCEED 5 FPS VELOCITY WITHIN THE SERVICE LATERAL. SYSTEMS WITHOUT PUMPS, SHALL NOT EXCEED 10 FPS.
- ③ 17. UPON EMWD APPROVAL, VAULT DEPTHS GREATER THAN 5 FT SHALL INSTALL LADDER PER B-519 OR B-520. ("DANGER" PERMITTED CONFINED SPACE DO NOT ENTER) SHALL BE PAINTED ON THE VAULT LID PER EMWD SPECIFICATIONS.

② ③ ③ NOTE: ALL MATERIALS SHALL MATCH THE SERVICE LATERAL PIPELINE SIZE EXCLUDING BYPASS LINE.

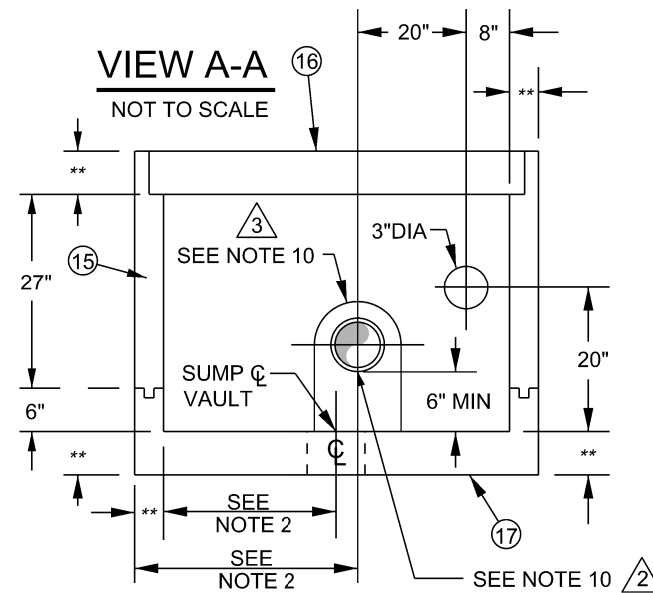

| REVISIONS | | | | | | APPROVALS | | |
|-----------|----------|---------|---|-------|---------|--------------|---------|---------|
| NO. | DATE | INITIAL | DESCRIPTION | APP'D | DATE | | INITIAL | DATE |
| ③ | 6-12-15 | GS | ADDED FLOW RATE TABLE, TEST PORT, B-976 REFERENCE TO NOTE 5, MATERIAL LIST, AND NOTES 11, 12, 13, 14, 15, & 16. | AGA | 6/19/15 | DESIGN | JVS | 12/9/85 |
| ② | 10/30/06 | RE | ADDED NOTE # 10 & MATERIAL LIST # 18 WATER STRAINER & KNOCKOUT HOLE LOCATIONS | JM | 11/2/06 | CONSTRUCTION | JDA | |
| | | | | | | INSPECTION | | |
| | | | | | | OPERATIONS | DWA | |
| | | | | | | SUBMITTED | LM | 2/10/86 |



EASTERN MUNICIPAL WATER DISTRICT
STANDARD DRAWING

8" METER INSTALLATION

REFERENCES: REPLACES B-581
FILE I.D.: \kauai\eng\std dwgs\B-636.dgn
SCALE: NONE
DRAWN BY: SKD

APPROVED James H. Bunts, Jr 2/12/86
DATE

B-636

