

FLOW RATE TABLE

METER SIZE	FLOW RATE (GPM)	EMWD STD DWG	LATERAL SIZE	VELOCITY (FT/S)	METER LENGTH
5/8" MULTI-JET	15	B-590	1 1/2"	2.79	7 1/2"
3/4" MULTI-JET	20	B-590	1 1/2"	3.72	7 1/2"
1" MULTI-JET	30	B-591	1 1/2"	5.59	10 3/4"
1 1/2" MULTI-JET	75	B-342	1 1/2"	SEE NOTE 13	13"

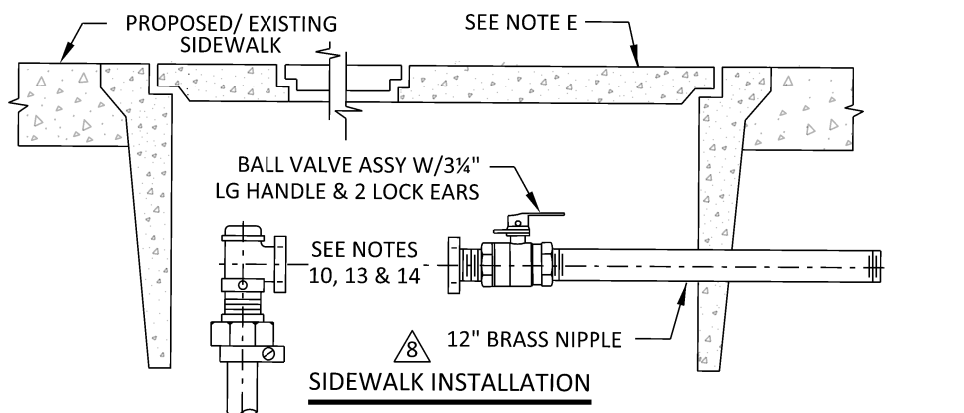

- NOTES:**
- ALL FITTINGS INCLUDING, BUT NOT LIMITED TO, THE CORPORATION STOP AND ANGLE STOP VALVE SHALL:
 - BE MADE OF BRASS OR BRONZE;
 - BE OF THE BANDED PATTERN;
 - BE DESIGNED FOR A MIN OF 175 PSI (COLD) WATER WORKING PRESSURE.
 - PRESSURE TEST PER EMWD SPECIFICATIONS.
 - ALL BARE IRON AND STEEL SHALL BE COATED WITH CEMENT MORTAR PER EMWD SPECIFICATIONS.
 - ALL LISTED MATERIALS TO BE PER EMWD APPROVED MATERIALS LIST.
 - CORPORATION STOP, FITTINGS, AND SERVICE LINE WITHIN 3 FEET OF SADDLE SHALL BE PRIMED & WRAPPED WITH PROTECTO WRAP OR APPROVED EQUAL.
 - ALL SERVICE PIPE AND TUBING SHALL BE LAID ON A POSITIVE SLOPE UP FROM THE WATER MAIN TO THE METER. NO DIPS OR POCKETS IN LINE WILL BE PERMITTED. 36" COVER AT GAS MAIN CROSSINGS.
 - THREAD NOTATION SHOWN THUS:
 - IP = IRON PIPE THREAD.
 - CS = CORPORATION STOP (MUELLER).
 - CT = COPPER SERVICE THREAD.
 - PJ = PACKING JOINT.
 - METER BOX SHALL BE EMWD APPROVED COMPLETE WITH TWO-PIECE COVER AND LID WITH AMR/AMI ANTENNA PORT PER METER STANDARD DRAWING. (SEE NOTE F FOR SIDEWALK INSTALLATION).
 - VALVE BOX, IF REQUIRED, SHALL BE PER METER STANDARD DRAWING.
 - CONTRACTOR SHALL RETURN AFTER ROAD SHOULDER OR PARKWAY IS COMPLETE TO INSTALL METER BOX, AND SHALL BE RESPONSIBLE FOR COORDINATING WORK OF OTHER CONTRACTORS FOR SAFEGUARDING SERVICES UNTIL METER BOXES ARE SET.
 - SYSTEMS WITH ONSITE PUMPS SHALL NOT EXCEED 5 FPS VELOCITY WITHIN THE SERVICE LATERAL. SYSTEMS WITHOUT PUMPS, SHALL NOT EXCEED 10 FPS.
 - FOR 5/8", 3/4" OR 1" METER INSTALLATION, USE A 1 1/2" X 1" COPPER SWEAT REDUCER WITH A 1" METER ANGLE STOP. 1 1/2" COPPER SERVICE LATERAL TO BE REDUCED TO 1" COPPER AFTER THE 90° TRANSITION. FOR 3/4" AND 3/8" METER INSTALLATION, USE A 1" METER ANGLE STOP. SEE MANUFACTURER'S SPECIFICATIONS FOR METER INSTALLATION.
 - FOR SINGLE FAMILY RESIDENTIAL UNITS, ENGINEER TO VERIFY THE ADEQUACY OF THE SERVICE LATERAL SIZE TO ALLOW FOR OPERATION OF RESIDENTIAL FIRE SPRINKLER SYSTEM. FOR COMMERCIAL AND INDUSTRIAL APPLICATIONS, SERVICE LATERAL SIZES WILL BE BASED ON VELOCITIES BEING UNDER 10 FT/S.
 - JUMPER ASSEMBLY USED FOR THE CONSTRUCTION OF THE METER SERVICE SHALL BE MADE OF SCHEDULE 80 PVC, HAVE ALL PVC FITTINGS SOLVENT WELDED, AND MEET METER MANUFACTURER'S SPECIFICATIONS FOR METER INSTALLATION. JUMPER TO BE PAINTED BLUE (POTABLE JUMPERS ARE NOT TO BE USED FOR RECYCLED WATER SERVICE CONNECTIONS).
 - SERVICES THAT REQUIRE BACKFLOW PROTECTION PER EMWD'S ADMIN CODE, SHALL BE PER B-597.

PLACEMENT OF METER BOX

- PLACE FRONT EDGE OF METER BOX 6" BEHIND EXISTING OR PROPOSED 6' OR 8' SIDEWALKS.
- WHEN PROPOSED OR EXISTING SIDEWALK IS 12' WIDE, PLACE FRONT EDGE OF BOX 1.5' BEHIND CURB USING APPROPRIATE BOX.
- WHEN NO SIDEWALK IS PROPOSED, PLACE FRONT EDGE OF METER BOX 6.5' BEHIND CURB.
- UPON COMPLETION OF WATER SYSTEM, WHEN NO CURBS ARE EXISTING NOR WILL BE INSTALLED, PLACE BACK EDGE OF METER BOX ON PROPERTY LINE.
- WHEN INSTALLED IN CONCRETE (SIDEWALK), SEE METER STANDARD DRAWING FOR METER BOX INSTALLATION SPECIFICATIONS.
- A MINIMUM 5' SEPARATION IS TO BE MAINTAINED BETWEEN THE SEWER LATERAL, WATER SERVICE AND RECYCLED WATER SERVICE.

REVISIONS				APPROVALS			EASTERN MUNICIPAL WATER DISTRICT STANDARD DRAWING	
NO.	DATE	INITIAL	DESCRIPTION	APP'D	DATE	INITIAL	DATE	1-1/2" COPPER SERVICE CONNECTION
9	9/29/22	GS	REMOVED PJ COUPLING, ADDED SWEAT COUPLING, MOD. NOTE 5	AGA	9/29/22			
8	4/6/22	GS	REMOVED, REVISED AND ADDED NOTES, ADDED REDUCER,	AGA	12/30/16	DESIGN		
			UPDATED FLOW RATE TABLE, REMOVED CONDUIT DETAIL AND ADDED SIDEWALK INSTALLATION DETAIL			CONSTRUCTION		
7	12/21/16	GS	UPDATED LOGO AND NOTE 1, 6, AND 11	AGA	12/30/16	ML	10/23/95	
			REFERENCES:					
			FILE I.D.:					
			SCALE: NONE					
			DRAWN BY: KER					
				RECOMMENDED		Joseph D. Van Sickle 10/20/95		
						APPROVED		
						G. Novite Ruyge 10/20/95		
						DATE		
						B-342A		