

- NOTES:**
1. "T" INDICATES THE THICKNESS OF THE STEEL PIPE WHERE THE TYPICAL DETAIL IS CALLED OUT.
  2. BEFORE WELDING, DRILL AND TAP NUMBER OF HOLES AS NOTED FOR 1/4" PIPE. CONTRACTOR TO PLUG WELD HOLES ON COMPLETION OF JOINT TEST.
  3. DETAIL APPLIES TO EITHER COLLAR OR WRAPPER.

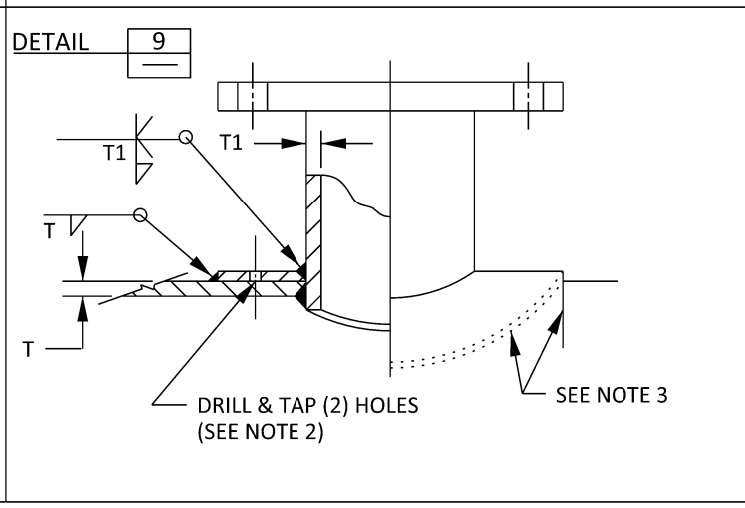

REVISIONS				APPROVALS			EASTERN MUNICIPAL WATER DISTRICT STANDARD DRAWING	
NO.	DATE	INITIAL	DESCRIPTION	APP'D	DATE	DESIGN	INITIAL	DATE
						DESIGN	KER	1/18/96
						CONSTRUCTION		
						INSPECTION	RPK	1/18/96
						OPERATIONS		
						SUBMITTED	VJB	1/18/96
1	5/6/19	GS	UPDATED TITLE BLOCK, FONT AND LOGO	AGA	5/6/19			
REFERENCES:				SCALE: NONE			EASTERN MUNICIPAL WATER DISTRICT	
FILE I.D.: \kawaii\eng\std dwgs\B-659.dgn				DRAWN BY: KER			RECOMMENDED	
				Charles J. Bachmann			1/19/96	
				DIRECTOR OF ENGINEERING			DATE	
				APPROVED			G. Hooite Ruge	
				ASSISTANT GENERAL MANAGER			1/25/96	
							DATE	
							B-659	

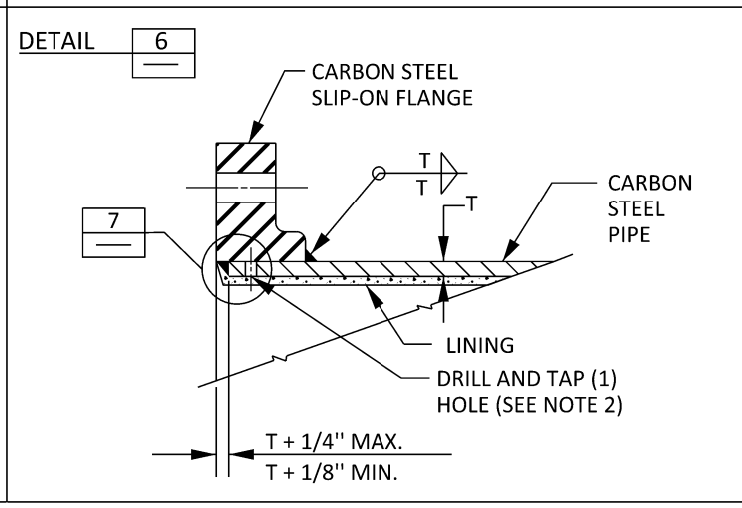
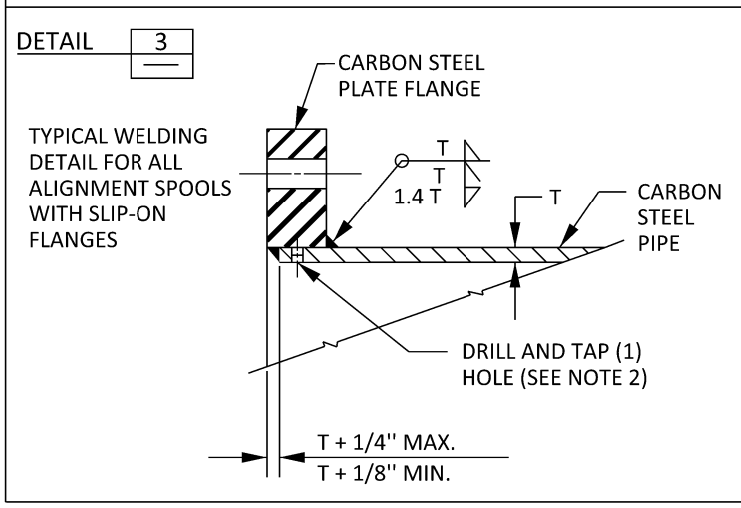
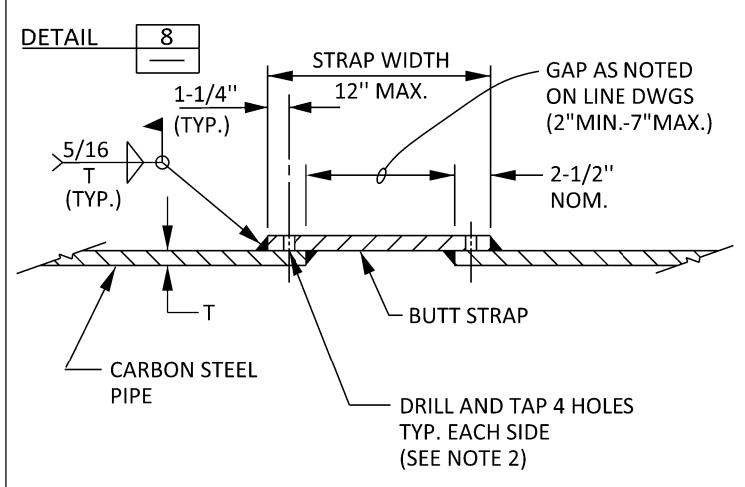
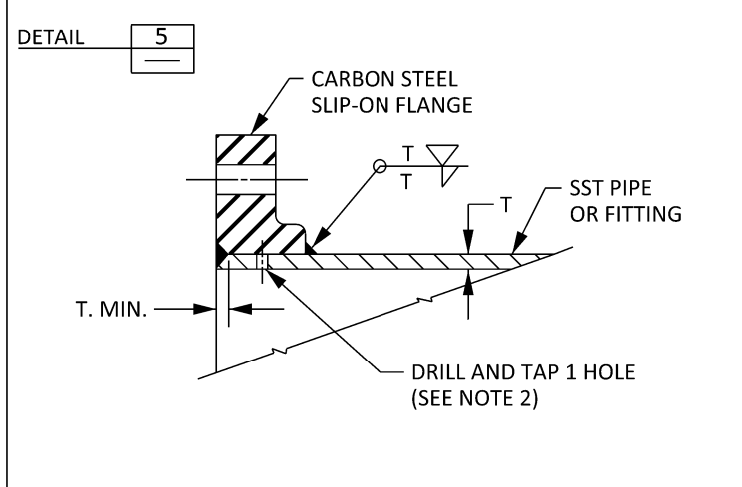
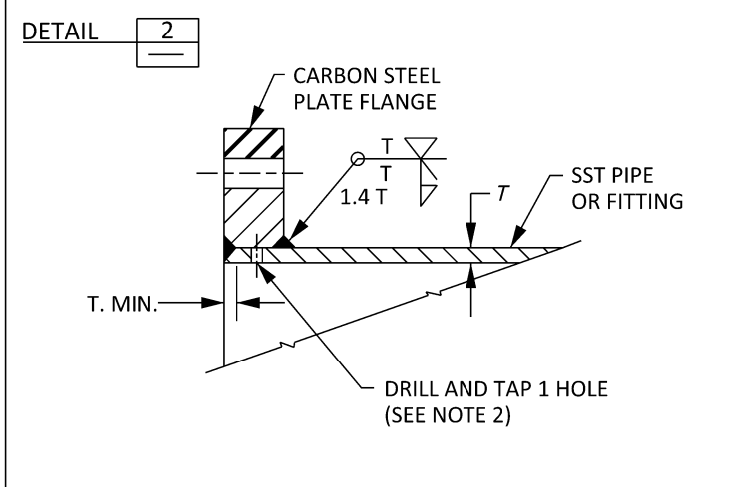

**AIR TEST DETAILS**